



CENTRE FOR MATERIALS FOR ELECTRONICS TECHNOLOGY,
(A Scientific Society, Ministry of Electronics and Information Technology, Govt. of India)
SHORANUR ROAD, M.G. KAVU, P.O. ATHANI, THRISSUR 680 581, Kerala, India
Tel No.: 0487 – 2201156-59; Fax 0487 – 2201347
Email : cmett@cmet.gov.in URL : www.cmet.gov.in

TENDER NOTICE

Sealed Tenders are invited in two parts; technical bid and financial bid, from either the Principal/OEM itself, or by Agent/Dealer on behalf of the Principal/OEM, for the supply, installation, commissioning and demonstration of stores mentioned below, in the tender format attached herewith.

S.No	Brief Description of Stores	Tender No.	Qty
1	Fiber Optic Spectrometer with Accessories – <i>Detailed specification is given in Annexure-II</i>	TR/PUR/SP/059/2017	1 unit
Due date of Tender	25.04.2018 at 15.00 hrs		
Date of Tender Opening	25.04.2018 at 15.30 hrs The tender would be opened at 15.30 hrs on the due date, at the address mentioned above		
EMD	Rs.35,000/- (Rupees Thirty Five thousand only)		

The General terms and conditions shall be as per the **Annexure -I** attached herewith.

Tender (Financial bid) shall be prepared in the prescribed format.

The techno-commercial bid and financial bid shall be kept in separate covers and put in a single cover superscribing the **enquiry reference number and name of the item and date of tender opening**. Please submit your quotation **on or before 15.00 hrs on the due date**, in accordance with the terms and conditions.

Our Provisional GST No. is 32AAAAC0801E1ZS

Sd/
Administrative Officer

Limited Tender Format

Name of the Firm :

Firm Registration No. (If any)		Date			
GST No.		PAN (Attach photocopy)			
Phone	Address :				
Fax					
Email					
URL					
Tender Schedule : All rates in Figures and in Words in Rupees					
Tender No. and Date					
Sr. No.	Description and Specification	Qty	Unit	Rate per unit	Amount
Packing / Forwarding charges					
GST					
Total value					
Delivery Terms					
Delivery Schedule :					
Enclosed Specifications/Drawings/Special Conditions of Contract :					
Item /Tender Specific Conditions of this Tender :					
<p>I/we engage to supply the material(s) to your office and comply the following</p> <ol style="list-style-type: none"> 1) Tender schedule and technical specification indicated 2) Item/tender specific conditions for this tender 3) Terms and conditions printed overleaf 4) General conditions of contract signed by me at the time of supplier registration (for registered suppliers) 5) I/we confirm that set off for the GST paid on the inputs have been taken into consideration in the above quoted price and further agree to pass on such additional duties as sets offs as may become available in future under GST 6) This offer is valid for 90 (ninety) days from the date of opening of the tender 7) That we have not been debarred by any Government /Undertaking 8) That the rates quoted are not higher than the rates quoted for same item to any Government/ Undertaking 9) That the bid submitted by us is properly sealed and prepared as to prevent any subsequent alteration and replacement. 					
Signature & Seal Place & Date		Name of Authorised Signatory			
Address		Tel. No/Fax No/ Mobile No. Email id			

TERMS AND CONDITIONS

1. The tender shall be submitted by either the Principal/OEM itself, or by Agent/Dealer on behalf of the Principal/OEM, but both cannot bid simultaneously for the same product in the same tender. If an agent submits bid on behalf of the Principal/OEM, the same agent shall not submit a bid on behalf of another principal/OEM in the same tender for the same item/product.
2. The quotation must be in the form furnished by Procuring Entity (C-MET) and should be free from corrections/erasures. In case there is any unavoidable correction it should be properly attested; if not, the quotation will not be considered. Quotation written in pencil will not be considered.
3. Bidders are required to submit their quotation in two envelopes. The first envelop, called the techno-commercial bid, shall contain EMD and the eligibility, technical quality and performance aspects, commercial terms and conditions and documents sought in the tender, except the price and relevant financial details. In the second envelop, called the financial bid, the price quotation along with other financial details are submitted. Both the envelopes are to be submitted together in a sealed outer envelope.
4. The specifications for the items quoted should be explicitly clear and all available technical literature, catalogues and other data in support of the specification of the items should be furnished along with the quotation.
5. Only one quotation should be sent in one envelope for a specified equipment/instrument.
6. Quotation should be valid for a minimum period of Ninety Days from the due date.
7. **Earnest Money Deposit (EMD)**
 - a) E.M.D or Bid Security in Indian Rupees for Rs. 35000/- (Rupees Thirty five thousand only) should be deposited by the Bidder, in any one of the following forms, along with the Technical bid:-
 - i. Call Deposit Receipt duly endorsed in favour of C-MET or Pay Order or Demand Draft in favour of C-MET
 - ii. Fixed Deposit Receipt issued by Nationalised banks endorsed in favour of C-MET, Thrissur.
 - b) The EMD shall be put in a separate envelope superscribing tender reference no. as such on it and put in the envelope containing technical bid as described in terms and conditions at Sl. 3. In the absence of EMD the Bid will not be accepted.
 - c) The Earnest Money Deposit will be returned along with necessary endorsement for payment to the bidder (without interest) whose offers are not acceptable to C-MET after placing the final order.

- d) The EMD shall also be forfeited:
- i) if a Bidder withdraws its bid or increases rates during the period of Bid validity specified by the Bidder on the Bid Form ;
 - ii) or in case of a successful Bidder, if the Bidder fails:
 - a) to accept the Purchase Order or refusal to execute the tender after it has been awarded or obligations under the same are not fulfilled; or
 - b) to furnish the performance security deposit in accordance with terms and conditions at sl. 26.
 - iii) EMD exemption : The firms which are registered with DGS &D and the Micro and Small Enterprises (MSE) which are registered as MSE with any agency mentioned in the notification of the Ministry of Micro, Small and Medium Enterprises, indicated below are exempted from EMD:-
 - a) District Industries Centres;
 - b) Khadi and Village Industries Commission;
 - c) Khadi and Village Industries Board;
 - d) Coir Board;
 - e) National Small Industries Corporation;
 - f) Directorate of Handicraft and Handloom; and
 - g) Any other body specified by the Ministry of MSME

The exemption is subjected to furnishing of relevant valid certificate for claiming exemption and shall be kept along with Techno-Commercial Bid.

8. The quotation should reach **on or before 25th April, 2018 by 15.00 hrs** , to the Administrative Officer, C-MET, (Centre for Materials for Electronics Technology, Shornur Road, Mulankunnathukavu (P.O), Athani – 680 581, Kerala State, India super scribing **Name of the Item , Tender Reference No., Due date**. The Techno-Commercial bid will be opened on 25th April, 2018 at 15.30 hrs at C-MET, Thrissur.
9. C-MET reserves the right to accept the offer by individual items and reject any or all tenders without assigning any reason thereof and does not bind itself to accept lowest quotations.
10. Manufacturer's name and country of origin of materials offered must be clearly specified. Please quote whether your organization is large scale industry or small scale industry. If you have NSIC/MSE/MSI/DGS & D Certificate. Please attach it to the quotation . Mention your registration details.
11. Complete details and ISI specification if any must accompany the quotation. Make/brand of the item shall be stated wherever applicable. If you have got any counter offer as suitable to the material required by us, the same may be shown separately.
12. Samples must be submitted where specified along with the quotations. Samples must be carefully packed, sealed and labeled clearly with enquiry number, subject and sender's name for easy identification. Rejected samples, will be returned at your cost if insisted.

13. All drawings sketches and samples, if any, sent along with this enquiry must be returned along with quotations duly signed .
14. All supplies are subject to inspection and approval before acceptance. Manufacturer/supplier warranty certificates and manufacturer/Government approved lab test certificates shall be furnished along with the supply, wherever applicable.
15. C-MET reserves the right to modify the quantity specified in this enquiry.
16. The prices quoted shall be in Indian Rupees and should be firm till the supplies are completed. Please quote the rates in words and figures. Rates quoted should be free delivery at destination including all charges otherwise the quotation is likely to be rejected. Prices quoted for free delivery at destination will be given preference. If there is no indication regarding the FOR, in the quotation, then it will be considered as FOR destinations. Price quoted should be net and valid for a minimum period of three months from the date of opening of the quotation.
17. In case the items in the enquiry are covered by any rate contract or running contract finalized by the DGS & D or any other state or central Government, it should be specified in your quotation and accepted contract rates should also be mentioned. It should be confirmed whether you could supply at the RC rates outside rate contract.
18. Payment of GST; in the case of supplier registered under GST, is primarily responsibility of the seller and will not be paid unless the percentage value is clearly mentioned in the quotations. If no indication regarding GST is recorded in the quotation, the GST will be considered as included.
19. Delivery period required for supplying the material should be invariably specified in the quotation.
20. In case your quotation is accepted and order is placed on you, the supply against the order should be made within the period stipulated in the order, C-MET reserves the right to recover any loss sustained due to delayed delivery by way of penalty. In case of failure to supply within the time specified in the Purchase order, a penalty/LD of 0.5% of the total value per week or a part thereof shall be levied subject to a maximum of 10% in respect of items which are not supplied. The decision of C-MET shall be final in this regard.
21. If the deliveries are not maintained and due to that account Procuring Entity (C-MET) is forced to buy the material at your risk and cost from elsewhere, the loss or damage that may be sustained there by will be recovered from the defaulting supplier.
22. Dispute clause: Any dispute relating to the enquiry shall be subject to the jurisdiction of the court at Thrissur only.
23. Our normal payment terms are 100% (hundred percent) within 30 (thirty) days on receipt and acceptance of material at our site in good condition.

24. Evaluation of Tenders

- a. All tenders are evaluated strictly on the basis of the terms and conditions incorporated in the tender document and those stipulated by the tenderers in their tenders. Tenders that do not meet the basic requirements specified in the bid documents are treated as unresponsive and ignored.
- b. Evaluation is based only on the conditions included in the tender document and any other condition will not form the basis of this evaluation.
- c. **Evaluation of eligibility/qualification Criteria:** Procuring Entity will determine, to its satisfaction, whether the tenderers are eligible, qualified and capable in all respects to perform the contract satisfactorily. Tenders that do not meet the required eligibility/qualification criteria prescribed will be treated as unresponsive and not considered further.
- d. **Evaluation of Technical Suitability:** The description, specifications, drawings and other technical terms and conditions are examined with respect to the specifications Procuring Entity. Minor exceptions/deviations may be waived provided they do not constitute any material deviation and do not have significant financial impact and, also, would not prejudice or affect the ranking order of the price bid. Exceptions/deviations should not grant the tenderer any undue advantage vis-à-vis other tenders and Procuring Entity.
- e. **Evaluation of Commercial Conditions:** The commercial conditions quoted by the Tenderer are evaluated to confirm that all terms and conditions specified in the Tender have been accepted without reservations by the tenderer. Only minor deviations may be accepted/allowed, provided these do not constitute material deviations without financial impact and do not grant the tenderer any undue advantage vis-à-vis other tenders and Procuring Entity.
- f. **Evaluation of Financial Bids and Ranking of Tenders in general:**
 - a) The financial bids of only responsive and technically accepted tenders will be opened and evaluated.
 - b) If the price bid is ambiguous so that it may very well lead to two equally valid total price amounts, then the bid should be treated as unresponsive.
 - c) Sometime certain bidders offer suo motu discounts and rebates after opening of the tender (techno-commercial or financial). Such rebates/discounts should not be considered for the purpose of ranking the offer but if such a firm does become L1 at its original offer, such suo motu rebates can be incorporated in the contracts. This also applies to conditional rebates, for example, rebate for faster payments, and so on.
 - d) Normally, the comparison of the responsive tenders shall be on total outgo from the Procuring Entity's pocket, for the procurement to be paid to the supplier or any third party, including all elements of costs as per the terms of the proposed contract, including any taxes, duties, levies etc, freight insurance etc. Therefore it should normally be on the basis of FOR destination basis, duly delivered, commissioned, as the case may be.
 - e) Unless otherwise specifically indicated as inclusive in the total price, if any of the bidders has failed to quote any cost element; such as freight, packing charge etc., the highest of the charge quoted by other parties shall be taken for comparison and ranking.
 - f) In the case of bidders who are not registered with GST, the price comparison shall be after adding reverse tax payable by Procurement entity.
 - g) In the case of goods manufactured in India or goods of foreign origin already located in India, GST and other similar taxes and duties, which will be contractually payable (to the tenderer) on the goods are to be added.
 - h) As per policies of the Government from time to time, the purchaser reserves his option to give price/purchase preferences as indicated in the tender document.

25. Procurement Preference :

- i. Procurement preference is given to Micro and Small Enterprises registered with any agency mentioned in the notification of the Ministry of Micro, Small and Medium Enterprises, indicated below, as per Public Procurement preference Policy of Govt. of India:
 - h) District Industries Centres;
 - i) Khadi and Village Industries Commission;
 - j) Khadi and Village Industries Board;
 - k) Coir Board;
 - l) National Small Industries Corporation;
 - m) Directorate of Handicraft and Handloom; and
 - n) Any other body specified by the Ministry of MSME
 - ii. The benefit is also available to MSEs, who are having Udyog Aadhar Memorandum
 - iii. This benefit is available only for procurement of only goods produced and services rendered by MSEs and not for any trading activities by them.
 - iv. An MSE Unit will not get any purchase preference over another MSE Unit.
 - v. Procurement Preference is also extended to suppliers registered under "Make in India" and where the minimum local content is 50%, as per Public Procurement (Preference to Make in India), order, 2017.
26. **Warranty clause :** The items covered under this tender, shall be covered minimum **one year** on site comprehensive warranty . Cost of **Extended warranty for two years** beyond one year of standard warranty may also be provided by the Supplier. The warranty shall be given by the Original Equipment Manufacturer. If any item covered under warranty fails, the same shall be replaced free of cost including all the applicable charges including transporting cost both the ways
27. On selection, he/she shall be required to provide security deposit as performance guarantee for an amount of 10% of the purchase value of the equipment(s) in the form of Demand Draft, Fixed Deposit Receipt or Bank Guarantee from the Nationalized bank, which shall be valid for entire performance guarantee period plus 60 days, within 14 days from the date of communication Purchase Order.

Sd/-
(Administrative officer)

Technical specifications

FIBER OPTIC SPECTROMETER WITH ACCESSORIES

Fibre optic spectrometer with accessories of reputed make suitable for the UV-Vis-NIR region is required for measuring the optical spectra coming through fibre optic cable. A reference figure indicating the application is attached at the end.

1. UV-Vis-NIR light source

Wavelength range	: 200-2500nm
Output cable for	: 600µm optical fibre cable (option 200 and 1000µm OFC)
Temperature range	: 5-35°C
Life time (Min)	: 1000hours
Power Supply	: 100-230V 50/60Hz AC

2. UV-Vis-NIR light detection system

Wavelength range range)	: 200-2200nm (Integrated/ two units with different wavelength range)
Input cable for 200	: 600µm optical fibre cable (option and 1000µm OFC)
Detector	: InGaAs array detector with cooling
Maximum Integration time	: Minimum 1 ms
Maximum signal to noise ratio	: 200-1000nm - 350:1 1000-2500nm - 1800:1
Resolution	: 200-1000nm ≤2nm 1000-2500nm ≤ 5nm
Sensitivity (In low noise mode) 150000count/µW/ms	: 200-1000nm - 1000-2500nm- 50000
count/µW/ms	
Stray light	: 1% Max

Interface : High speed USB 3.0/RS232
Power Supply : 100-230V 50/60Hz AC

3. Other items

- 1) Computer interface cables for spectrometers
- 2) User interface software with licence for data acquisition and analysis
- 3) Fibre optic cables for connecting to spectrometer and light source (SMA)
- 4) Basic connectors and other fixtures for efficient coupling with DUT, fibre optic switches and other fixtures

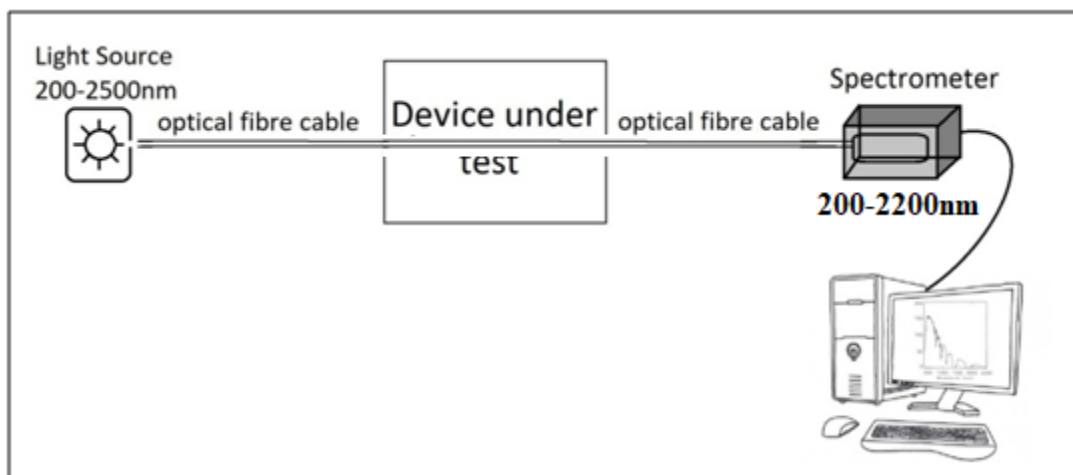

Schematic diagram indicating the application of fibre optic spectrophotometer

Optional Accessories

- Provision for analysis of thin film samples (reflectance and transmittance)
- Provision for analysis of liquid samples in standard cuvette

Other items

1. Operation manual in English
2. List of users in India should be supplied with the quote
3. Fibre optic spectrometer with accessories should carry warranty for minimum one year.
4. Extended warranty for two years beyond one year period should be provided as optional
5. Installation and training for using the system should be provided at C-MET Thrissur.
6. Compliance statement of specification should be submitted along with the offer.

Fibre optic spectrometer – C-MET requirements

Fibre optic spectrometer with accessories working in the UV-Vis-NIR region is required for measuring reflection spectra coming through standard fibre optic cable. The system should be capable of analysing transmittance and reflectance spectra of thin film samples. Also, provision should be there for analysing liquid samples in standard cuvette.

A schematic figure indicating C-MET's application is given below.

